

ADDVERB

Human | Robot | Possibilities

AUTOMATION SOLUTIONS THAT DELIVER VALUE



About Addverb

Addverb is a leading global robotics company that designs and delivers innovative warehouse automation solutions with intelligent robots, powered by modular software, that give a competitive edge to our clients by transforming their Supply Chain.

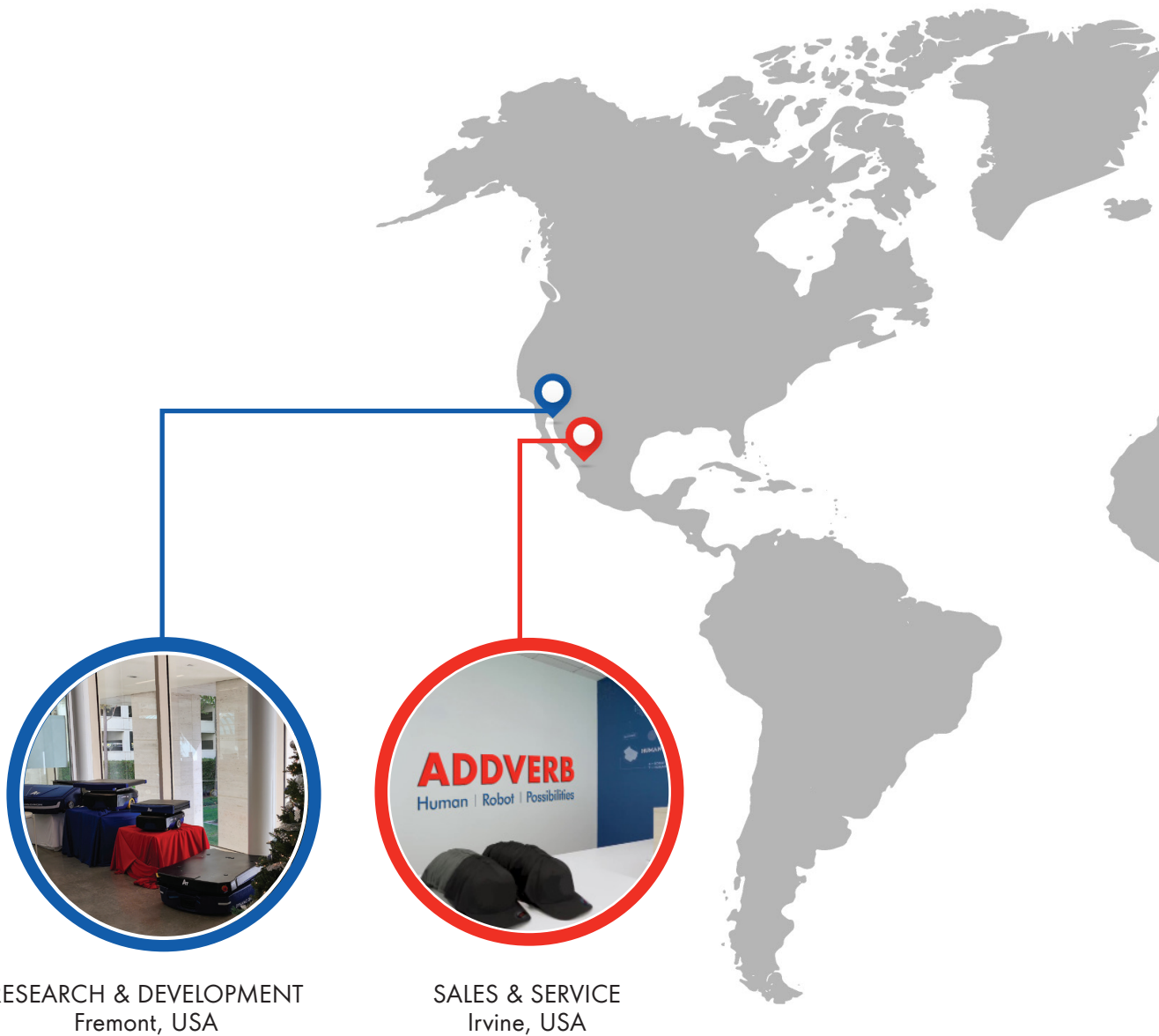

1400+
CARTON SHUTTLES

900+
MOBILE ROBOTS

400+
ASRS

350+
CLIENTS

SOFTWARE DEVELOPMENT CENTRE

- Noida, India
- Pune, India

MANUFACTURING

- Noida, India
- Gr. Noida, India

RESEARCH & DEVELOPMENT

- Noida, India
- Fremont, USA

SALES & SERVICE

- Irvine, USA
- Zoetermeer, Netherlands
- Dubai, UAE
- London, UK
- Paya Lebar, Singapore
- Kuala Lumpur, Malaysia
- Melbourne, Australia
- Sydney, Australia
- Cologne, Germany
- Aarhus, Denmark



Transforming Industries

Consumer Goods



E-Commerce & Retail

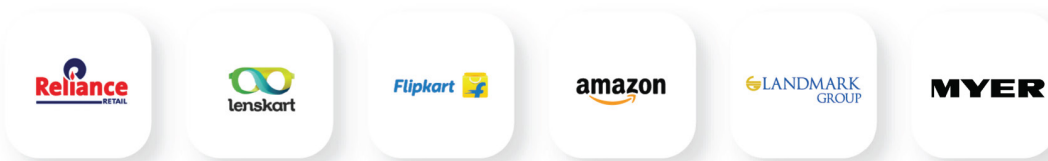

Fashion & Apparel



Electronics



Tyre



3PL



Automotive



Food & Beverage



Chemical



Petrochemical



Pharmaceutical



Others



Our Extensive Product Portfolio

Mobile Robots

Autonomous Mobile Robot
Multi-Carton Picking Robot
Autonomous Forklift

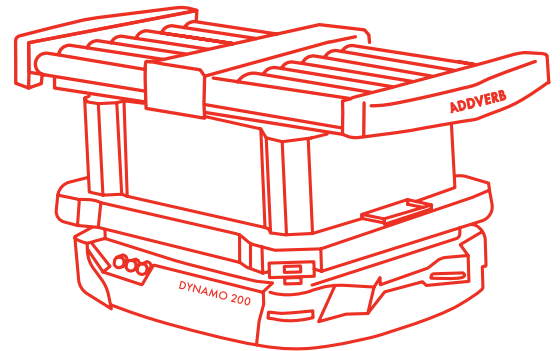

Sortation

Robotic Sorter
Zippy X
Zippy Tug
Vertical Sortation Robot

ASRS

Carton Shuttle
Multi-Level Shuttle
Mother-Child Shuttle System
Crane ASRS
Pallet Shuttle
4-way Pallet Shuttle

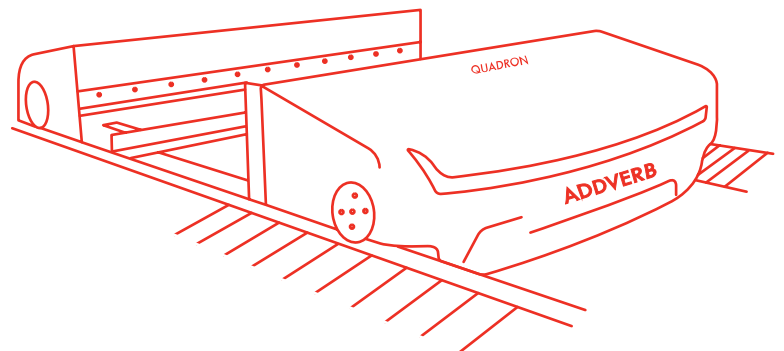

Picking

Pick-to-Light
Pick-by-Voice
Pick-by-Vision
Cobot

Conveyors

Case and Pallet Conveyors
Rail Guided Vehicle

Enterprise Software

Warehouse Execution System
Warehouse Management System
Warehouse Control System
Fleet Management System

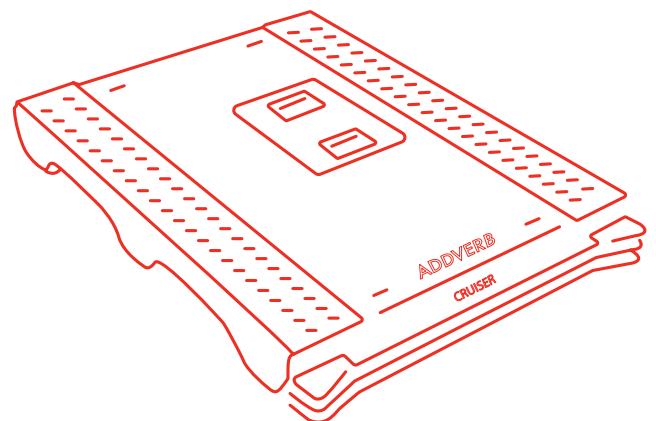

Mobile Robots

Powering your Business to Move Forward

Mobile Robots are equipped with on-board sensors, LiDARs, cameras, barcode readers, etc. that enable them to navigate their environment and interact with multiple objects and people. They are designed to collaborate with humans to perform strenuous and repetitive material movement tasks that maximise the efficiency and productivity of fulfilment operations.

Autonomous Mobile Robot (AMR)

Dynamo is our intelligent mobile robot that is enabled with 2D/3D LiDARs and powered by SLAM algorithms that help it to navigate complex landscapes in warehouses and factories. It adheres to global safety standards like EN 1525:1997 and ANSI/ITSDF B56.5-2019 that ensure safe conditions for workers who interact with these robots. Dynamo comes with a stiff industrial-strength chassis and compact design that make it more rugged and reliable. Dynamo can be configured for multiple warehousing applications like material movement, picking, and sortation. Through advanced AI techniques like machine learning and computer vision, it recognises and classifies objects, detects obstacles, and makes informed decisions in real-time that accommodate changing workflows and enable high-volume order fulfilment.

Payload (kg)

100, 200, 500,
1000, 1500, 2500

Speed

 Up to 2 m/s

Interoperability

VDA 5050 Compliant

Run time

 Up to 8 hours





Multi-Carton Picking Robot

Veloce is our adaptable Multi-Carton Picking Robot that enables high storage requirements of cartons, crates, and totes of varied sizes to create a space-saving and efficient goods to person solution. With the help of grid-based navigation, Veloce moves with ease through narrow aisles to perform double-deep storage and retrieval of cartons/ crates/totes with high-precision.

Payload

30 kg/level

Speed

 **1.5 m/s**

Height

5.5 m

Run time

 **Up to 5 hours**



Autonomous Forklift

FlowT, our Autonomous Forklift revolutionises material handling. Leveraging LiDAR-based SLAM for precise navigation, it ensures seamless movement in any warehouse environment day in, day out. It integrates dynamic pallet detection through camera-based systems. The ground-to-ground variant ensures efficient handling at floor level, while the ground-to-1.5m and ground-to-3m options extend its capabilities, reaching different elevations seamlessly, offering a solution for every logistical challenge.

With safety at its core, FlowT excels in both static and dynamic obstacle detection and avoidance, ensuring a safe and efficient workflow.

Designed for human collaboration, it establishes safety zones and fields. With hydraulic lift capabilities and customisable fork lengths, the autonomous forklift adapts to various load types, offering unparalleled flexibility. With seamless integration with the Fleet Management System (FMS) to streamline any logistical operations, FlowT sets a new standard in autonomous material handling, combining innovation with practical functionality.



Payload
1500 kg

Speed
 **Up to 1.5 m/s**

Run Time
Up to 8 hours

Lifting Height
 **3000 mm**

Sortation

Sorting your way to Success



Robotic Sorting is an integration of mobile robots, sensors, manipulators, and computer vision technology, that ensures fast and accurate sortation of diverse products with varied throughput requirements. Conventional sortation systems have complex design and integration requirements and need high initial capital and significant space. Robotic Sortation is a modular, adaptable, and cost-effective alternative to conventional sortation systems.

Robotic Sorter

Zippy, our high-speed robotic sorter, works on the concept of obstacle detection, using grid-based ground markers, to perform SKU-wise intelligent sortation at very high speeds. The flexible nature of the system allows seamless addition and removal of robots and sorting destinations to meet demand variability and optimise operations. It comes in two forms; table-top and floor-top. The table-top Zippy operates on tables with heights of up to 5 m, while the floor-top Zippy runs on the floor and features a long neck of up to 1.5 m, making it ideal for seamless integration with conveyors and case pallets.

Payload (kg)

Table-top 6, 10,
Floor-top 15(X), 25, 40

Speed

 Up to 2 m/s

Throughput

Up to 30,000 sorts/hour/system

Run time

 Up to 4 hours

Zippy X

Designed to maximise warehouse space utilisation, Zippy X utilises vertical lifting capabilities for flexible material handling and sortation, and to facilitate better ergonomics in manual operations. This ability with its modular load handling attachment helps to accommodate the parcels of different sizes, enabling efficient sorting into gaylords or bins of varying heights or into multi-level racks. With customisable solutions and adaptable applications, Zippy X sets a new standard for efficiency in sortation and material handling.



Zippy Tug: Efficient Material Movement



Zippy Tug is an advanced autonomous guided vehicle designed for material movement and tugging applications in various industrial settings. Operating with grid-based ground markers for precise navigation and obstacle detection, it seamlessly tows large loads and material. This industrial-grade robot optimises warehouse space with its compact footprint, minimum turning diameter and customisable paths.

Zippy Tug seamlessly integrates with existing equipment/trolleys, and its flexibility allows for efficient adaptation to demand variations, making it an ideal solution for warehouses, assembly lines, and large factories.

Payload

2000 kg

Speed

 **0.4 m/s**

Turning Diameter

1260 mm

Operating Temperature

 **5 to 45° C**



Vertical Sortation Robot

SortIE, our modular Vertical Sortation Robot travels on a dedicated track and efficiently sorts individual packets to their destination locations in different bin positions in a put wall. Its innovative design, efficient belt drive mechanism and precise motion control guarantee impeccable sortation. SortIE is ideal for quick commerce and reverse logistics, and can be easily expanded to meet increased demand. Each SortIE can serve up to 600 destinations, occupying the lowest footprint. The combination of Zippy and SortIE can work together to perform primary and secondary sortation.

Payload
2.5, 10 kg

Speed
 **Up to 3 m/s**

Individual Throughput
450 sorts/hour/robot

Destination Aisle Length
 **Up to 18 m**



ASRS

Storage Efficiency on the Rise



Automated Storage and Retrieval Systems are fixed advanced automation systems that allow precise storage and retrieval of carton and pallet loads. ASRS allows optimal utilisation of vertical space and enables high-density storage. These systems require special types of racking structures and ensure maximum throughput accuracy and operational safety.

Carton ASRS:

Carton Shuttle

Quadron, our versatile carton shuttle, automates the storage and retrieval of goods in cartons, crates, and totes weighing up to 50 kg. The shuttle-based storage system equipped with vertical lifts and specialised racking enables high throughput. Quadron allows double-deep storage, thereby enabling you to store, buffer, and sequence the inventory to enhance the productivity and increase the storage density of your distribution centre, it is an ideal feed system for a high-speed GTP station. Each aisle in the system can have up to 25 Quadrons reaching to a height of 20 m.

Payload

Up to 50 kg

Speed

 **Up to 4 m/s**

Operating Temperature

5 to 45° Celsius

Throughput

 **Up to 100 crates/hour/shuttle**

Multi-Level Shuttle

Medius is our dynamic multi-level shuttle system that performs efficient storage and retrieval of materials in cartons, crates, and totes weighing up to 50 kg. Medius can access 7 storage levels within a single aisle, eliminating the need for multiple shuttles at each level. It also enables a double-deep storage system that can reach a height of up to 4 m. With its compact design and lightweight construction, Medius offers advantages such as reduced maintenance and increased energy efficiency. It can be used in combination with Quadron to meet variable throughput requirements.

Payload

50 kg

Speed

 **Up to 3.1 m/s**

Space Utilisation

36 crates/sq. m

Throughput

 **70 crates/hour**

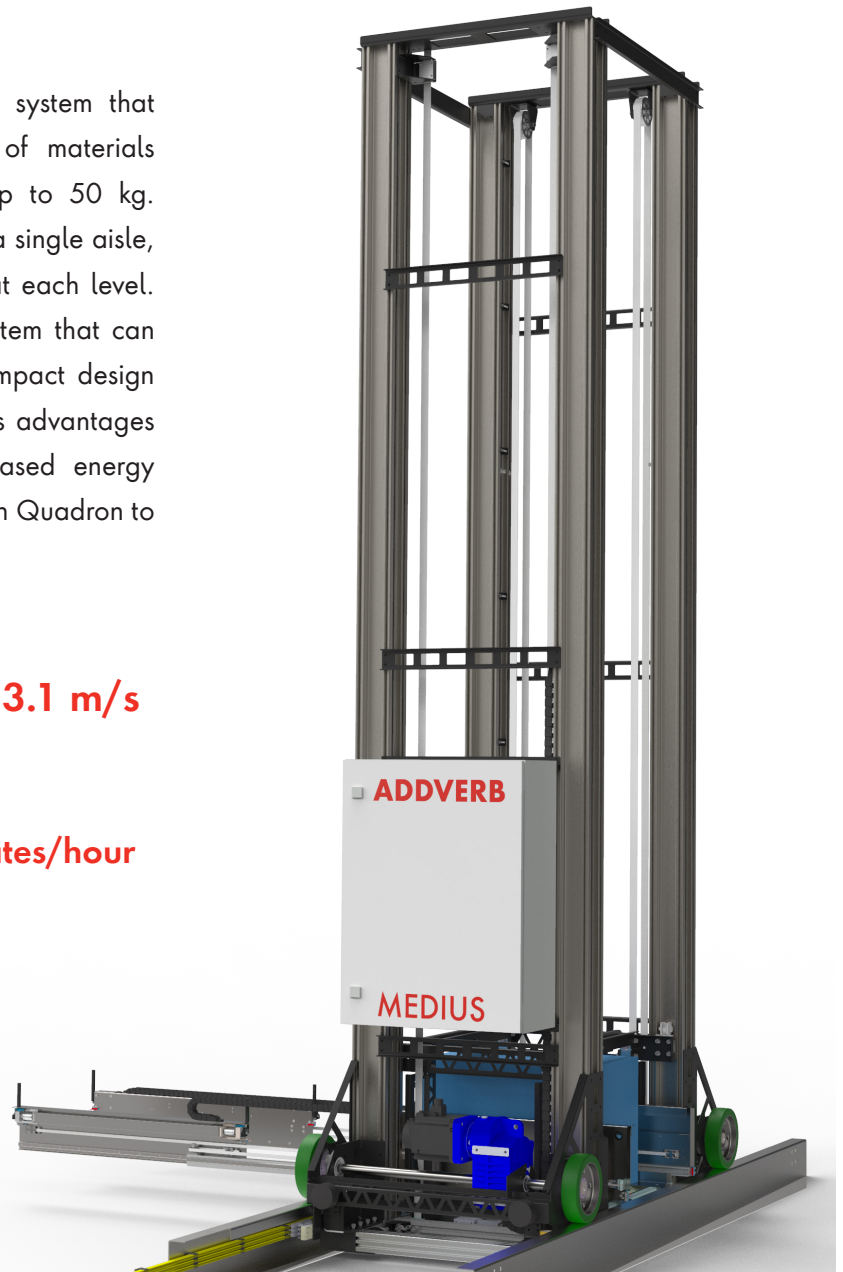

Pallet ASRS:

Mother-Child Shuttle System

Multi-Pro is our efficient shuttle based ASRS that offers higher throughput and allows greater storage density, making it ideal as an intermediate buffer between production and dispatch, and for storage of reserve inventory. The mother shuttle, powered by a bus bar, moves on a main track that spans the length of the storage system, and releases the child on a perpendicular storage track through which the child accesses individual storage locations. The child gets automatically recharged on the mother shuttle.

Features

- Suitable for pallet loads of up to 1500 kg
- High accuracy and real-time inventory visibility
- Modular design, built for heights of up to 40 m

Pallet Shuttle

Cruiser is our robust pallet shuttle that efficiently stores and retrieves pallets to maximise storage density and operational productivity. It moves along the storage lanes on a system of rails or tracks embedded within the racking structure, and lowers and lifts the pallet load to perform the storage and retrieval operations, respectively. The semi-automated system can be shifted to different aisles and levels by a fork-lift and reach truck. Cruiser can be controlled remotely through a Wi-Fi module, and is equipped with a replaceable lithium iron phosphate battery that is safer, offers a longer lifespan and a low discharge rate.

Features

- Mother shuttle offers a carrying speed of 3 m/s, and the child shuttle offers a carrying speed of 1.1 m/s
- Can carry a pallet load of up to 1500 kg, and can operate between -25 to 45 degrees Celsius
- Designed for the ease of maintenance and energy efficiency

Crane ASRS

Skyron, our proficient Crane-based ASRS is ideal for pallet handling and high-density storage requirements at heights of up to 40 m. Advanced controls and a robust build make the crane efficient and reliable, resulting in a high level of system availability and safe operations. The system is controlled by software that manages inventory accurately and coordinates safe and fast movement of cranes to optimise the storage and retrieval process. The modular design makes assembly and installation of these cranes fast and easy, and allows multiple configurations, such as single-deep, double-deep, or multi-deep, to meet business needs.

Features

- Can carry payloads of up to 1500 kg, with a carrying speed of 1.1 m/s
- High-density storage lanes as deep as 60 m, with FIFO and LIFO logic
- Can operate between -25 to 45 degrees Celsius

4-way Pallet Shuttle

Cruiser 360, our revolutionary 4-Way Shuttle ASRS, is designed for maximum efficiency, it optimises storage capacity by optimally utilising vertical space, accommodating up to 10 pallets per square metre. Its versatility shines through its ability to move items in both x and y axes and can move in z axis using lift to change levels, catering to dynamic warehouse needs. Customisable configurations ensure seamless integration with diverse layouts and storage requirements.

The in-house developed Warehouse Execution System enhances planning and coordination, while precise positioning and safety features ensure accuracy and security. Cruiser 360 embodies efficiency, flexibility, and reliability, offering a comprehensive solution for optimised warehouse operations.

Features

- Can carry payloads of up to 1500 kg, with a carrying speed of 1.5 m/s
- Can store and retrieve pallets based on FIFO and LIFO logic
- Operates in diverse conditions, from +5 to +45 degrees Celsius



Picking

Accurate Picking for Reliable Operations

Our Picking solutions are designed to increase the productivity of operators working in modern warehouses and satisfy the requirement for fast and accurate picking. Addverb's picking technologies can be easily integrated with existing infrastructure and software systems. The solutions ensure efficiency, reliability, and accuracy in picking operations, allowing businesses to create healthy bottom lines and

Pick-to-Light

Rapido is our reliable Pick-to-Light system that guides your workforce to pick the right products and quantities for an order, making it the fastest operator-based picking method for order fulfilment.



Pick-by-Voice

Zesty is our meticulous Pick-by-Voice technology that streamlines the order-picking process using voice commands to direct workers without paper or RF devices. It offers quick and accurate item picking and packing through real-time instructions with a user-friendly interface delivered with advanced speech recognition.



Pick-by-Vision

QuiMo is our cutting-edge vision-picking solution that provides hands-free access to critical order information and instructions using smart glasses and Augmented Reality (AR) technology. Workers can easily navigate the warehouse and identify items without language barriers or interruptions caused by noise.



Person-to-Goods Picking

Cobot



Syncro, our collaborative robot (cobot), engineered for seamless collaboration with human counterparts ensures enhanced safety, flexibility, and efficiency in shared workspaces. Equipped with advanced safety features, it fosters a secure working environment while offering unparalleled adaptability to diverse tasks. With user-friendly interfaces, programming and control become effortless, catering to operators of all skill levels.

Moreover, our Syncro is a cost-effective solution, making automation accessible to businesses of all sizes. From manufacturing lines to warehousing, its applications span across assembly assistance, quality control, material handling, and collaborative welding. Join the future of robotics with Syncro.

Payload

5 kg

Speed

 **1 m/s**

Reach

1000 mm

Material

 **Carbon Fibre**

Features

- Ensures safety through advanced features, minimising the risk of accidents
- User-friendly interface simplifies programming and operation for operators of all skill levels
- Easily adjusts to changing environments, offers dynamic performance in diverse settings

Conveyors

Conveying Excellence for Enhancing Warehouse Efficiency

Conveyors are used for efficient and fast material movement of varied unit loads like cases, crates, or pallets. With the help of advanced controllers and integration with PLC, and other smart sensors, conveyors can be configured for different applications and dynamic zoning, allowing for optimised material flow to ensure that cases and pallets are always transported to the right destinations at the right time.

Case Conveyors

Case Conveyors efficiently transport cases/crates from one area to another, reducing forklift traffic and labour requirements. With the help of advanced controllers, they enable internal tracking and dynamic zoning to facilitate complex material movement operations like merge, sort, divert, and accumulate. Our smart conveyors enhance picking ergonomics and provide a cost-effective solution for high-volume case transportation and distribution. They can be easily integrated with complex automated systems like ASRS, AMRs, sorting robots, enabling efficient sorting, buffering, and routing.

Features

- Can be easily integrated with other automation systems
- Proprietary controller with intelligent diagnostics and configurable for different modes
- Multiple applications like incline, decline, merge, sort, curve, divert, and accumulate

Pallet Conveyors

Pallet Conveyors play a crucial role in moving heavy loads efficiently within factories and warehouses. Utilising belts, chains, or rollers, these conveyors offer diverse modes of product movement. Their seamless integration with packing lines, ASRS, robotic palletisers, and other advanced machineries results in higher throughput and enhanced safety in factories and warehouses.

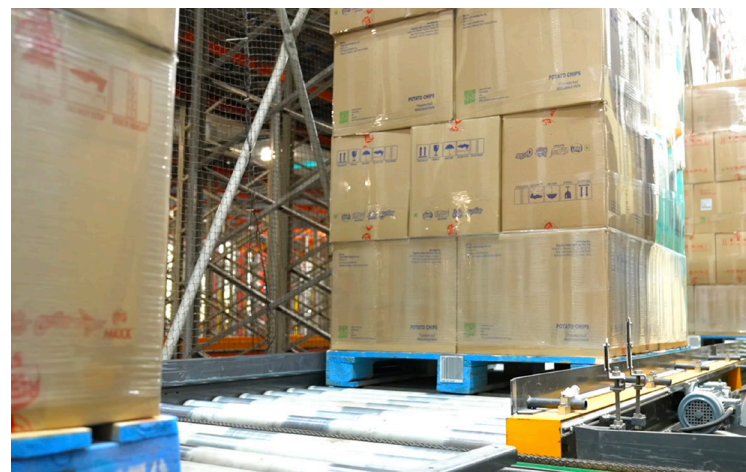

Features

- Seamless integration with palletisers, de-palletisers, and other automation systems
- Accommodates pallets, skids, tubs to perform varied functions
- High quality component and advance controls provides additional safety

Rail Guided Vehicle (RGV)

Travect is our efficient Rail Guided Vehicle that provides a fast, flexible, and reliable alternative for transporting pallets over long distances within warehouses and factories. Travect moves on a fixed-floor twin rail loop, ensuring quick and stable movement. The system can be expanded by adding multiple sources/destinations, and multiple Travect units can be added on the same rail loop to meet high volume and throughput requirements. PU-coating on cartwheels ensures quiet operations, while cleaning brush on rails provides protection against dust and dirt. Travect is ideal for high-throughput pallet handling requirements for Automated Storage and Retrieval Systems (ASRS).

Payload

1500 kg

Speed

 **Up to 3 m/s**

Track Width

850 mm

Acceleration

 **0.5 m/s²**

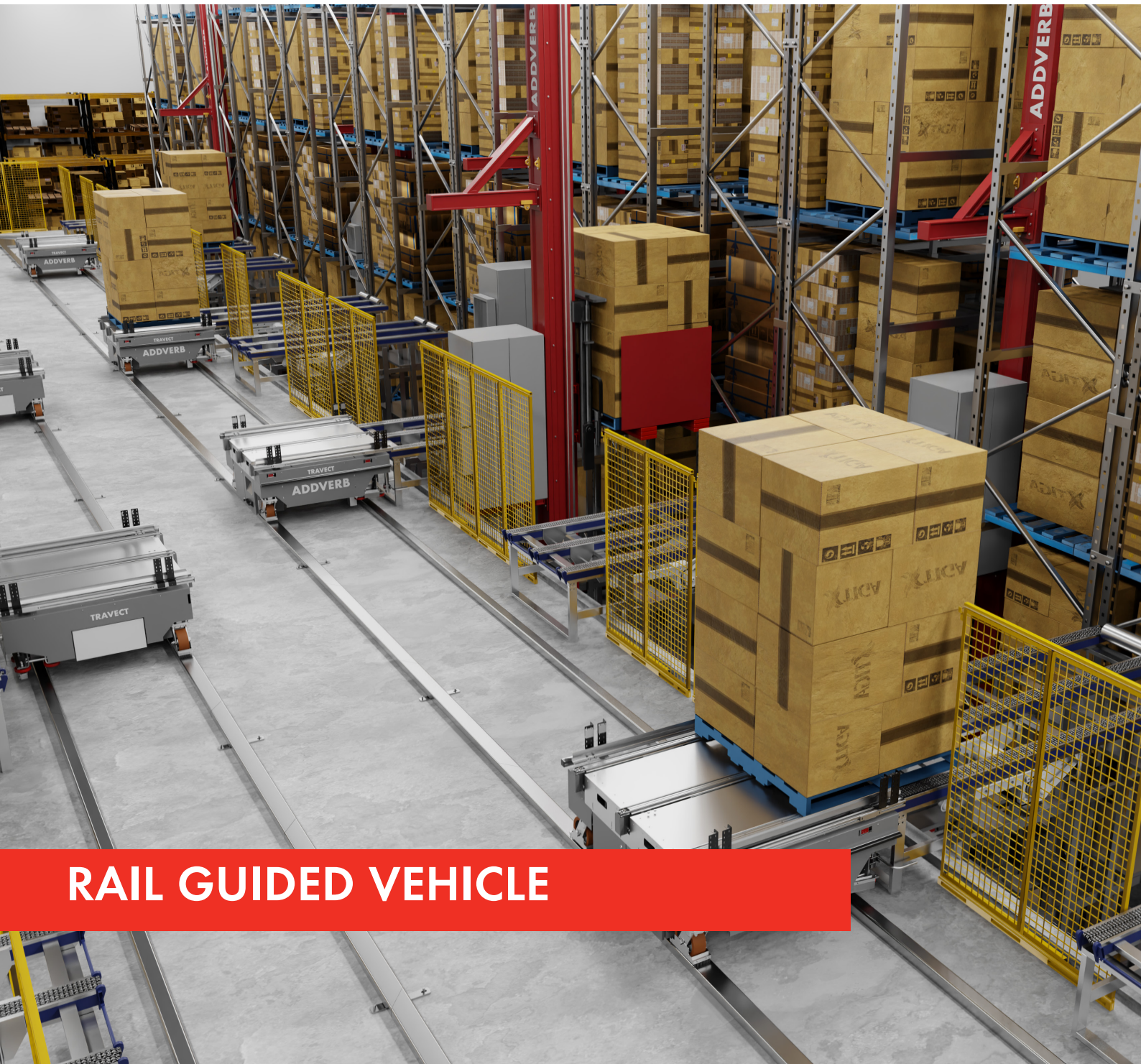

RAIL GUIDED VEHICLE

Enterprise Software

Adding Intelligence to Your Warehouse

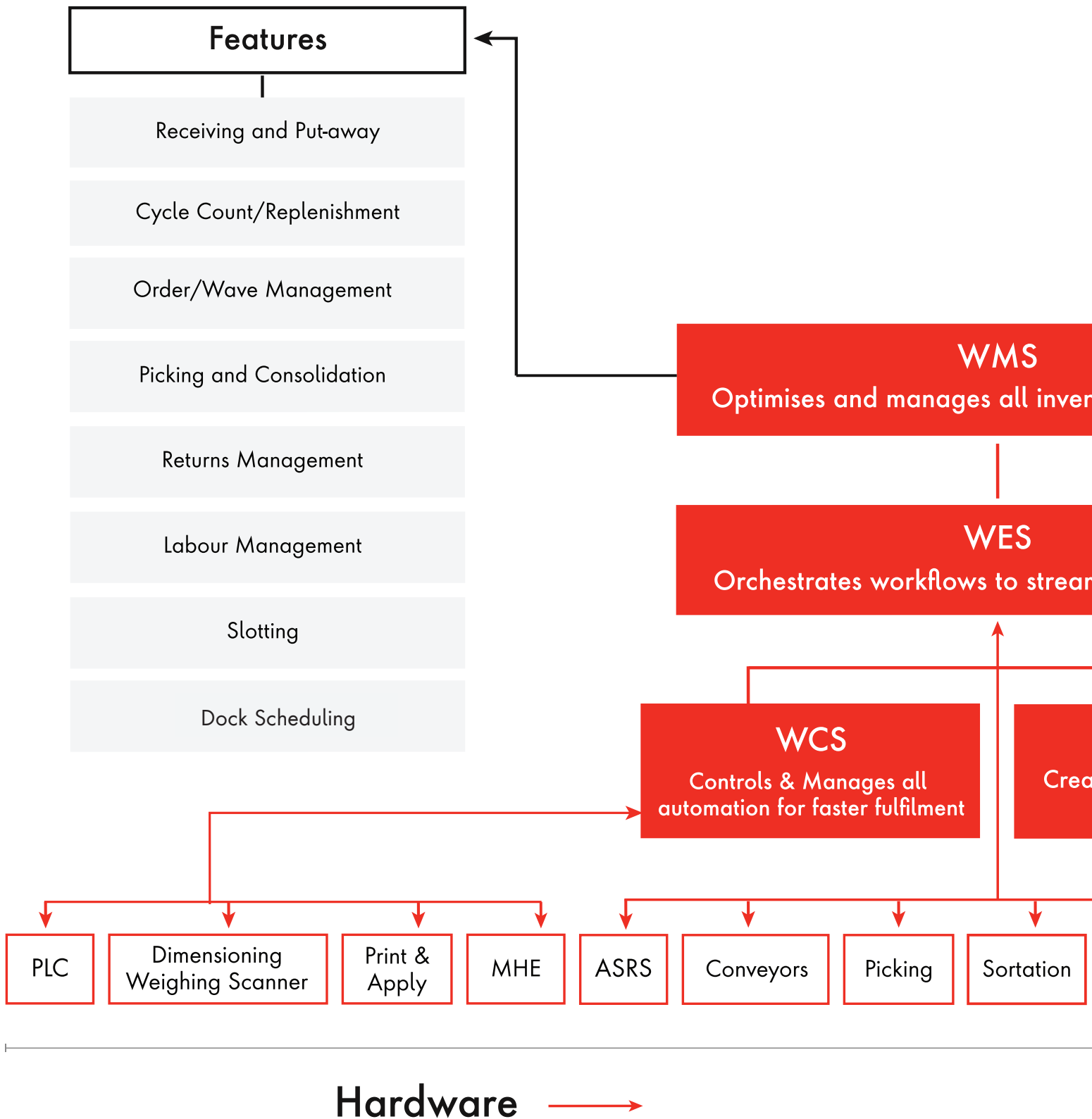

High order volumes, changing product mix, shrinking delivery timelines, and the pressure to lower the cost of fulfilment are driving businesses today to adopt flexible automation systems. These automation systems require configurable and high-performance software. Addverb's hardware-agnostic AI-powered software suite coordinates and orchestrates with different types of automation systems and robots seamlessly. It also effortlessly integrates with existing ERP/WMS/WCS systems.

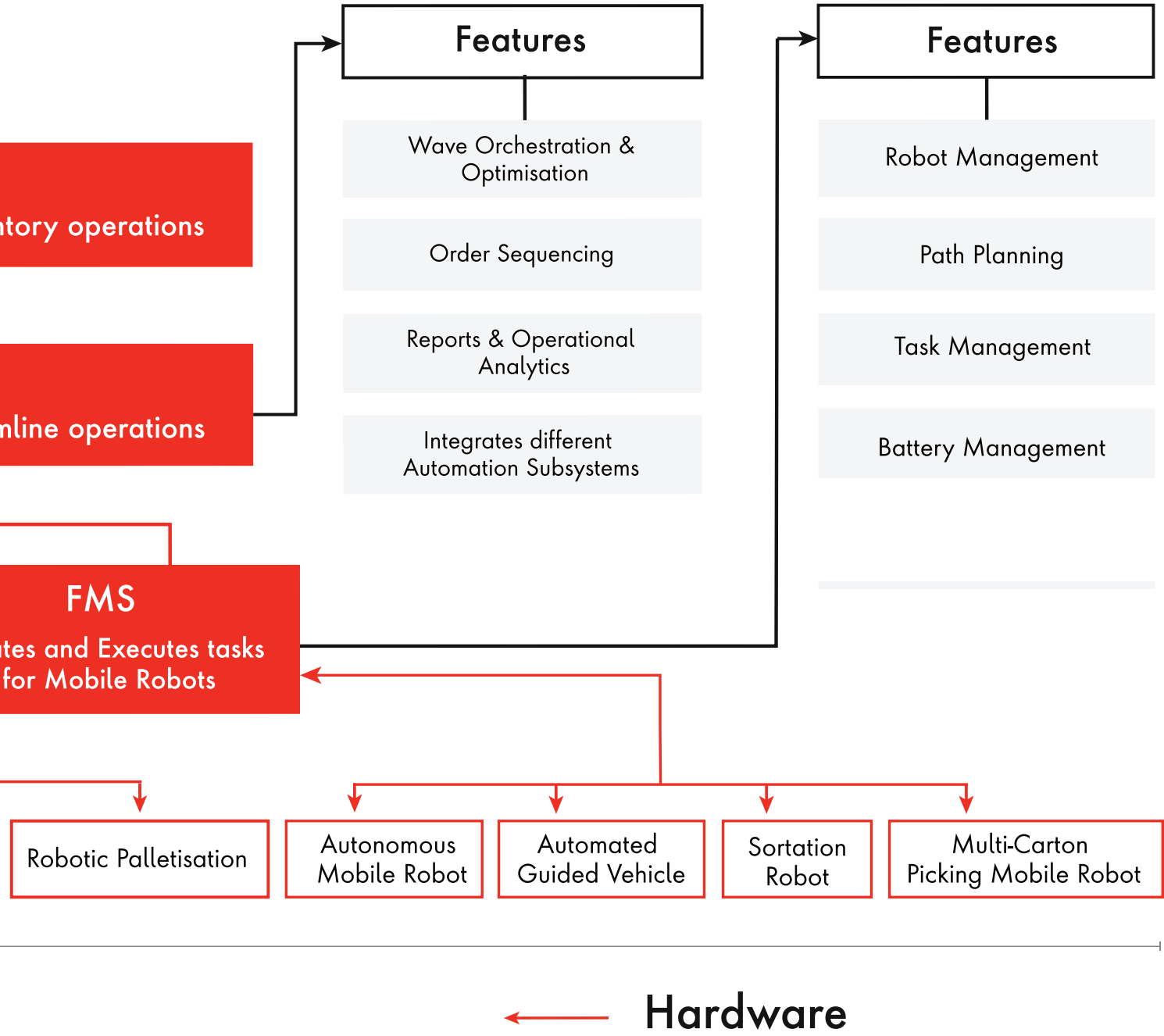

Warehouse Execution System

Concinity, our cloud-native Warehouse Execution System, is purpose-built to orchestrate and optimise warehouse operations to ensure efficient utilisation of resources and maximise productivity. Powered by AI and machine learning algorithms, Concinity creates intelligent workflows by evaluating equipment availability, picking priority, operational costs, inventory levels and ageing. It learns from each fulfilment cycle and optimises the order fulfilment for efficiency, reliability and accuracy.



Features

- Micro services-based architecture for plug-and-play implementation
- Intuitive and Easy-to-Use responsive UI for device-agnostic usage
- AI-driven optimisation engine to boost operations with complex order profile

Warehouse Management System

Optimus is our configurable Warehouse Management System that coordinates inbound and outbound logistics, controls inventory, manages resources, and balances workload to ensure seamless operations. Engineered with a microservices architecture, Optimus is highly adaptable and modular, and it can be integrated with any upstream ERP or order management system, providing real-time order and inventory status updates.

Features

- Supports advance customisations at business logic level
- Easily scalable, can cater to a mix of complex automated systems
- Cost-effective and rapid deployment



Warehouse Control System

Mobinity is our powerful, modular, and scalable Warehouse Control System that interfaces with various equipment and automation systems to control and optimise the movement of goods. Mobinity provides comprehensive reporting and analytics that enable the monitoring of KPIs, identification of bottlenecks, and data-driven decision-making to optimise warehouse operations.

Fleet Management System

Movect, our robust Fleet Management System, can centrally manage and support multiple fleets of robots from different vendors through effective coordination, accurate control, and efficient scheduling. Using advanced AI-powered algorithms, it optimises multi-robot path planning to ensure better traffic control, and increases throughput by creating an efficient robot-task combination.

Features

- Seamless integration with upstream systems like WMS, WES, ERP, etc.
- Offers real-time visibility into stock availability
- Hardware-agnostic and modular design

Features

- Optimal Task Allocation to each robot as per the order quantity
- Dynamic path planning using heatmap to avoid traffic congestion
- Real-time monitoring of the location, status, battery level and tasks of each robot

Lifecycle Support

Comprehensive Assistance Guaranteed



Addverb's Lifecycle Support delivers high quality Customer Experience on a global scale through tailored packages customised to meet the needs of different industries, and ensures peak performance of automation systems. Our experienced professionals work closely with you to optimise and upgrade your systems with ease, minimising downtime and reducing operational costs.

Key Features

- **Computerised Maintenance Management System (CMMS):** We offer full-fledged CMMS for managing assets, and its preventive and breakdown maintenance.
- **Tailored Packages:** Choose from a range of options; on-site support, remote support, annual maintenance contracts (AMC), diverse spare parts and preventive maintenance packages, and site audits to check for upgrades and optimisation.
- **24x7 Support:** Our team of seasoned professionals is available round-the-clock to meet your urgent repairs and troubleshooting requirements.
- **Analytics and Insights:** Our scenario-based approach coupled with advanced data analytics helps us to create a service strategy that will minimise your breakdowns and downtime.
- **After Sales Training:** We offer on-site learning, e-learning engagement, and gamification-based training for continuous learning and growth of your service team.



#AddverbAdvantage

EFFICIENCY | RELIABILITY | ACCURACY

ADDVERB

Human | Robot | Possibilities



Recognised By



FROST &
SULLIVAN

Gartner



MATERIAL
HANDLING **247**
FROM MATERIAL HANDLING PRODUCT NEWS MAGAZINE